



PROVEN PERFORMER

Vended Laundry

SWNNX2 (top loading washer),
SDENXR (electric dryer), SDGNXR (gas dryer)

Top loading washer features

- 710 rpm spin speed among the highest in the industry
- Curved four-vane agitator delivers an industry-best 210° stroke
- Exclusive stainless steel tub with a lifetime warranty
- Helps protect against pulls, snags or frayed clothes
- Fast cycle times

Dryer features

- Durable galvanized steel cylinder with an extra-large 198 litres of volume
- Efficient dryer heating with 6,300 kCal (gas models) and up to 4,000 Watts (electric models)
- Extended tumble helps eliminate wrinkling
- Quiet, efficient blower system uses a superior airflow of 5100 litres per minute
- 1913.8 sq. cm door opening is the largest in the industry, providing easy loading and unloading for customers



EASY OPERATION



STANDARD STAINLESS STEEL DRUM



LARGE DOOR OPENING



LOW ENERGY CONSUMPTION

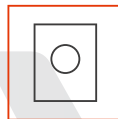

ROBUST DESIGN

Controls

Quantum™ Gold

In addition to its network capabilities and off-site management features, Quantum™ Gold offers additional owner and customer benefits such as PC programming and machine audit capabilities, as well as time-of-day pricing, a “lucky cycle” for loyal customers and the ability to interface with the store owner’s payment systems. Cycle modifier keys create additional profit opportunities for store owners.



SWNNX2

SDENXR, SDGNXR

	SWNNX2	SDENXR (Electric) SDGNXR (Gas)
Type	Top Loading Washer	Single Dryer
Control	Quantum	Quantum
Control location	Rear	Rear
Drum		
Capacity kg	7.3	8.2
Cylinder volume litres	92.3	198
Drum speed		
Spin speed G-Force	150	n/a
Spin speed rpm	710	n/a
Motor		
Motor size kW	0.37	0.25
Cabinet		
Cylinder finish	Stainless steel	Galvanized
Colours	White	White
Door type (solid/window)	n/a	Solid
Heating		
Heat sources	n/a	Gas or Electric
Heating element (Electric W)	n/a	4000
Connection		
Gas inlet connection mm	n/a	9.5
Gas consumption BTU/Hr	n/a	25,000
Exhaust outlet dia. mm	n/a	102
Exhaust airflow litres/sec	n/a	60 Hz: 105, 50 Hz: 85
Water temperatures	3	n/a
Operation		
Cycles*	Normal, Perm Press, Delicate	High, Medium, Low, Delicates, No Heat
Water consumption per cycle litres*	93.0	n/a
Water pressure bar	1.4/8.3	n/a
Cycle indicator lights	Yes	Yes
Power		
Electrical requirements (voltage/Hz/Ph)	240/50/1	240/50/1
Transport data		
Net weight kg	86	Electric/Gas 61/64
Shipping weight kg	95	Electric/Gas 66/68
Dimensions H×W×D mm	1092×650×711	1092×683×711
Packing dimensions H×W×D mm	1124×699×762	1156×737×832
Agency approvals	See price sheet for applicable agency approvals by market	
Available agency approvals		



Dimensions

Top Loading Washer

	A	B	C	D	E	F	G	H	I	J	K	L
SWNNX2	651	745	730	1092	914	547	570	1025	1085	1295	660	711

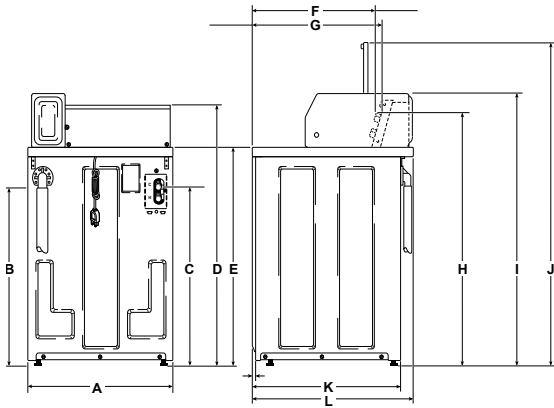

Electric Dryer

	A ¹	A ²	B ¹	B ²	C	D	E	F	G	H	I	J	K	L	M
SDENXR	548	560	1020*	970	1097*	392*	102*	391	683	914*	114*	10	203	711	597

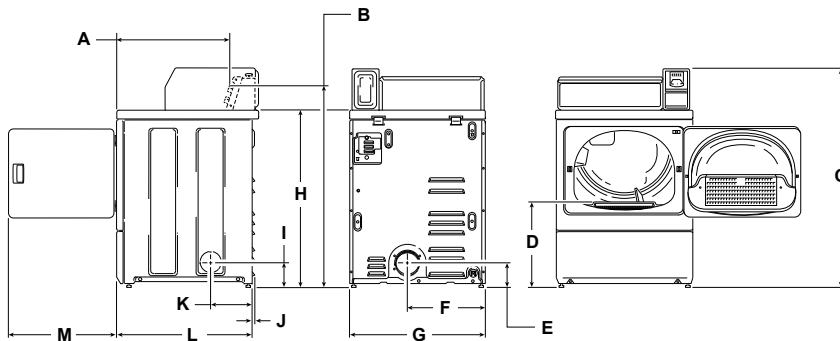

Gas Dryer

	A ¹	A ²	B ¹	B ²	C	D	E	F	G	H	I	J	K	L	M	N	O
SDGNXR	548	560	1020*	970	1097*	392*	70*	60	391	683	102*	914*	114*	10	203	711	597

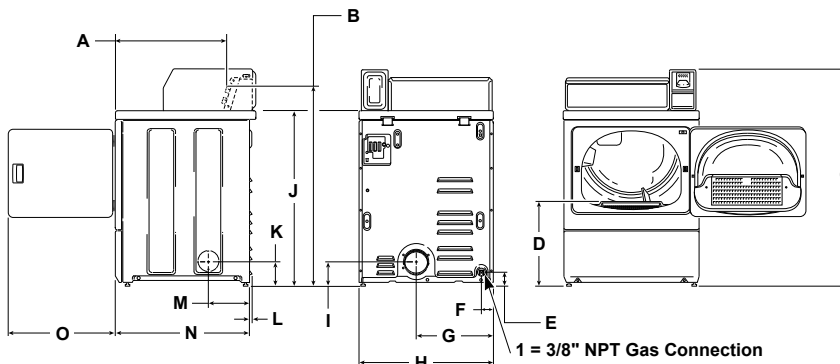

NOTE: Gas models cannot be vented out left side of cabinet because of burner housing.

IMPORTANT: The dryer should have sufficient clearance around it for needed ventilations and for the ease of installation and servicing. For maximum drying performance, we recommend that more clearance be allowed around the dryer than the clearances that are listed here.

All measurements are in mm. *With levelling legs turned into base. ¹Coin Slide models. ²Electronic Control models.
 NOTE: Exhaust openings are 102 mm metal ducting.

