



COMMERCIAL LAUNDRY SYSTEMS

TITAN-C



TITAN-C

Washer

		Non-Heater
CYLINDER		
Drum Volume	cu.ft (l)	5.16 (147)
Capacity	lb (kg)	33 (15)
DIMENSIONS		
Product (WxHxD)	in.(mm)	29 (737) x 40.8 (1,036) x 32 (814)
With Door Opening	in.(mm)	53 (1,370)
Weight (Product/Carton)	lb (kg)	221.8 (100.6) / 248 (112.5)
SPEED		
Wash	RPM	50
Extract (High Speed)	RPM	980
SYSTEM & CONTROL		
Inverter Direct Drive Motor		•
Intelligent Electronics Controls		•
3 Compartment Dispenser		•
Gravity Drain System		•
Pricing Program		Special Vended Price
WASH PROGRAMS		
		Hot
		Warm
		Cold
		Delicates
		Add Super Wash
Program List		
EXTERNAL FINISH		
Drum		NeveRust™ Stainless Steel Drum
Top Plate		Porcelain (Single)
Transparent Glass Window Door		•
Colors		Platinum
Cabinet		Painted Steel
Control Panel		Painted Steel
Window Display		Silk Screen
Window		Aluminium
CIRCUIT PROTECTION		
PCB Fuse - Main Control Board	amps	12
PCB Fuse - Filter Assembly	amps	15

	Non-Heater		
	Coin	Card	On Premise
Single	F10C7FD4 TCW2013QS	F10C7FD7 TCW2013CS	F10C7FD3 TCW2013LS
Stack	-	-	-

* Dimensions and weights are approximate.
 * Design, features and specifications subject to change without notice.
 * Some models may not be available for sales in certain countries.

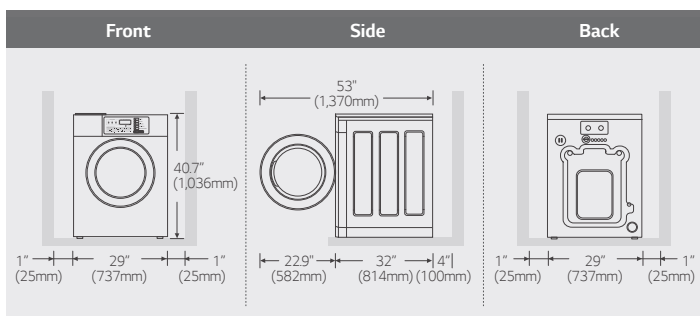

Dryer

		Gas
CYLINDER		
Drum Volume	cu.ft (l)	9.0 (254)
Diameter	in.(mm)	28.2 (716)
Depth	in.(mm)	24.2 (614)
Capacity	lb (kg)	30 (13.6)
DIMENSIONS		
Product (WxHxD)	in. (mm)	29 (737) x 40.2 (1,022) x 42.9 (1,090)
With Door Opening	in. (mm)	65.1 (1,655)
Carton (WxHxD)	in. (mm)	30.7 (781) x 44.7 (1,137) x 44.4 (1,128)
Weight (Product/Carton)	lb (kg)	220 (100) / 240 (108.8)
OPERATION		
Electric Requirements	V/Hz/amps	120/60/10
Heating Type		Gas
Type of Drying	W	Ventilation
Drum Motor	KW	0.5 (120V/60Hz)
Fan Motor	KW	0.3
Gas Ratings	KW/BTU	16.1 (EU) ¹⁾ /55,000
CONNECTIONS		
Air Outlet Diameter	in.(mm)	6 (154)
Exhaust Airflow Diameter	in.(mm)	6 (154)
SYSTEM & CONTROL		
Pricing Program		Special Vended Price
Intelligent Electronic Controls		•
DRY PROGRAMS		
		High Temp
		Med Temp
		Low Temp
		No Heat
Program List		
EXTERNAL FINISH		
Top Plate		Porcelain (Single) / Painted Steel (Stack)
Transparent Glass Window Door		•
Colors		Platinum
Cabinet		Painted Steel
Control Panel		Painted Steel
Window Display		Silk Screen
Window		Aluminium

	Gas	
	Coin	Card / On Premise
Single	RN1870AN4 TCD1870QGS	RN1870AH4 TCD1870CGS
Stack	RN1870AN2 TCD1870QGG	RN1870AH2 TCD1870CGG

* Dimensions and weights are approximate.
 * Design, features and specifications subject to change without notice.
 * Some models may not be available for sales in certain countries.
 1) Gas rating is different by countries.

