

MLE21PN

EXPORT MODEL
STACK WASHER/DRYER



LEGENDARY MAYTAG DEPENDABILITY

Maximizing your equipment investment for over a half century.

A COMPLETE LINE OF ENERGY-EFFICIENT SOLUTIONS

Maytag brand offers a complete line of high-efficiency commercial laundry appliances—from energy-efficient dryers to highly efficient ENERGY STAR®-qualified washers—to help you save money and build profits.

MICROPROCESSOR CONTROLS

Maytag® Computer Trac controls are easy to program and operate. Plus, they give owners the flexibility to set vend prices by day, time, water temperature and Super Cycle options.

SAVE SPACE AND CUT UTILITY COSTS

A Maytag® commercial stack washer/dryer gives you a full-size high-efficiency washer and a super-capacity dryer in the space of a washer alone.

FOR YOUR CUSTOMERS:

- Single Payment System
- Large Capacity For Bulky Items—3.1-cu.-ft. Capacity Washer/ 6.7-cu.-ft. Capacity Dryer
- High-Speed Extraction Cuts Drying Time (up to 1,000 RPMs)
- 180° Door Opening With Heavy-Duty Die-Cast Hinge
- Display Panel Angled For Easy Viewing
- Easy-To-Use, One-Touch Cycle Selection
- Quick Cycle Reduces Total Wash Time

FOR YOUR OPERATION:

- Super Cycle Option Increases Revenue
- Accu Trac® Audit System With Two-Way Data Communication
- Card Reader Compatible
- Automatic Load Balancing
- Built-in Oversudsing Protection
- TurboVent™ Dryer Technology
- Reversible Door, Dryer Only

BUILT-TO-LAST™ FEATURES:

- Precision Endurance Drive
- 5-Year Limited Warranty—All Parts Covered



Visit maytagcommerciallaundry.com or call 800-662-3587



MLE21PN
EXPORT MODEL
STACK WASHER/DRYER
MICROPROCESSOR CONTROLS

WASHER SPECIFICATIONS	
EXPORT MODEL	MLE21PN
MOTOR	
Variable-speed, reversible, thermoprotected, high-efficiency, controlled induction	Yes
Wash—HP (kw)	.09 (.07)
Extract—HP (kw)	.54 (.40)
Average washer energy consumption per cycle (kWh)	0.054
CAPACITY	
Cylinder volume—cu. ft. (liters)	3.1 (88)
Cylinder diameter—in. (mm)	21.6 (547)
Cylinder depth—in. (mm)	13.4 (340)
WATER INLET/HOSE	
Inlet hose length/drain hose length—ft. (m)	4 (1.22)/6 (1.83)
Water supply pressure—psi (bar)	20–100 (1.4–6.9)
APPROXIMATE WATER USAGE—GALLONS (LITERS)	
Average hot water usage, hot water cycle	3.3 (12.5)
Average hot water usage, warm water cycle	1.3 (4.9)
Average total water usage per cycle	11.96 (45.3)*
SPEED	
Wash speed—RPM	40
Extract speed—max RPM/max g-force	1,000/306
SOUND LEVEL	
Sound pressure level, Lpa (dBA) (Kpa: ± 3.6 dBA)	58
DRYER SPECIFICATIONS	
MOTOR	
Variable-speed, reversible, thermoprotected, high-efficiency, controlled induction	Yes
HP (kw)	.33 (.25)
Tumble speed—RPM	50 ± 1
CAPACITY—CU. FT. (LITERS)	
	6.7 (190)
HEATING ELEMENT RATING	
MLE electric export models—watts	4,600
AIRFLOW	
MLE electric models—cfm (cmm)	215 (6.1)
MACHINE SPECIFICATIONS	
ADJUSTABLE LEVELING LEGS	Yes
COLOR	White
APPROXIMATE WEIGHT	
Crated—lbs (kg) electric/gas	383 (173)/389 (176)
Uncrated—lbs (kg) electric/gas	372 (169)/378 (171)
DIMENSIONS	
Width—in. (mm)	27 (686)
Depth—in. (mm)	29.5 (749)
Height—in. (mm)	74 (1,880)
Door opening—washer—sq. in.	143
Door opening—dryer—sq. in.	191
ELECTRICAL REQUIREMENTS—VOLTS/HZ**	220–240V/50Hz
BREAKER/FUSE MINIMUM REQUIREMENTS—AMPS	25A

*Average based on DOE J1 testing with factory preset cycles. Because of continuous product improvements, Maytag reserves the right to change specifications without notice.



5-YEAR LIMITED WARRANTY
ALL PARTS COVERED

For a period from the date of original purchase through the time listed above, the designated parts that fail in normal commercial use will be repaired or replaced free of charge for the part itself, with the owner paying all other costs, including labor, transportation and customs duty. Chemical damage is excluded from all warranty coverage. See complete warranty for details.

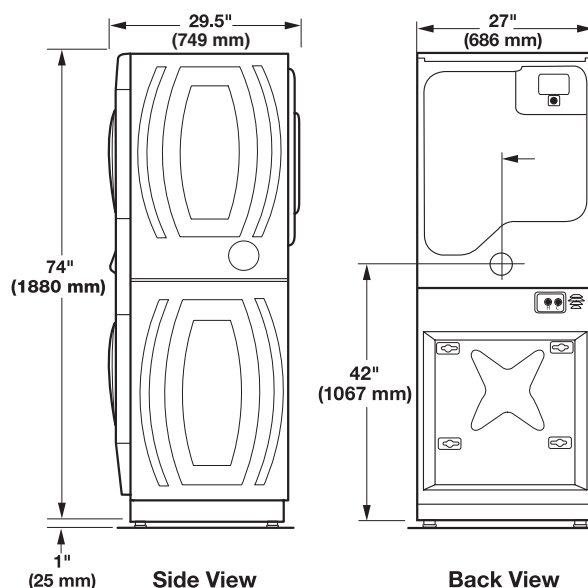

**It is recommended that a separate circuit serving only this washer/dryer be provided.



OUR COMMITMENT TO DEPENDABLE QUALITY

At Maytag brand, we believe durable goods should remain just that. That's why every Maytag® product is constructed of the highest-quality materials and with the utmost in precision craftsmanship. It's also why we stand behind our equipment with solid service and support from our professional Maytag laundry suppliers. Simply put, when you choose Maytag® products, you ensure your peace of mind.